

Design, Manufacturing and Communication for Packaging



ArtiosCAD

ArtiosCAD is the world's most popular **structural design software for packaging**. With dedicated tools specifically designed for packaging professionals for structural design, product development, virtual prototyping and manufacturing, ArtiosCAD increases productivity throughout your company. ArtiosCAD is the ideal product for all corrugated, folding carton and POP display **designers**.



ArtiosCAD's design and drafting tools include functions that structural designers need to get their job done accurately and efficiently. The **tool alignment and snapping** features provide graphical feedback, boosting productivity for both experienced and new users immediately become more productive. Complete **3D integration** allows for quick prototyping of designs and presentations, eliminating communication errors and reducing design review cycles.

Create plate layouts and die tooling – optimized for the production equipment that will be used in manufacturing - with ArtiosCAD's layout and tooling design features. The integrated database and reporting features enhance communication in your company as well as with external suppliers. ArtiosCAD's Adobe® Illustrator® plugins truly create the first round-trip workflow for structural and graphic designers.

Key benefits

- Superior drafting tools increase designer productivity
- Smart Standards save time and reduce errors
- 3D modeling and design provide fast prototyping and presentations
- Powerful and efficient layout and tooling design reduce production costs
- Relational database offers flexible library searches and report

Drafting built for productivity

Around the world, ArtiosCAD is proving that no other system delivers faster turnaround for your customers. Powerful drafting tools in **Designer** were created exclusively for designers and diemakers and use extensive graphical feedback, making ArtiosCAD easy to learn and use. Many of the design tools work automatically to help designers become more productive. For example, the Automatic Dimensioning tool can be used to automatically add dimensions to either an entire drawing or just a selected area.

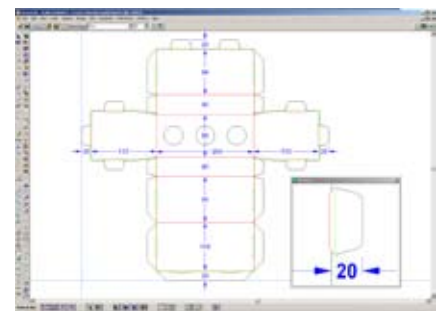

Smart Standards save time and eliminate errors

Create designs in seconds from the catalog of Standards using **Builder**.

A single Standard can be automatically resized to create thousands of basic parametric designs. **StyleMaker** saves hours of design work by turning custom designs into new reusable standards. Only ArtiosCAD has the tools to build a corporate library of Standards that improves quality and consistency while freeing designers for new creative work. **Advanced StyleMaker** lets designers build new Standards that include intelligent defaults, on-screen documentation, style alternatives and built-in error checking to ensure that everyone in your company uses each Standard correctly.

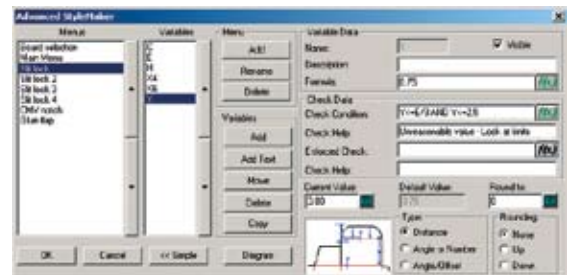
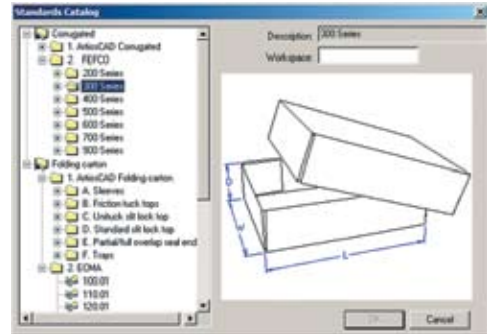

Accurate and realistic 3D models in minutes

Show your customers new designs as 3D models with ArtiosCAD 3D. Easily create assembly drawings: fold a base, drop in a header, fill with cartons and show the artwork. With **3D Animation**, you can even create 3D models that demonstrate how the packaging is folded or assembled. 3D is a powerful productivity tool for designers: even complex work is quickly and accurately folded with the unique Fold to Meet tools, and every design “remembers” how it was folded and animated. Users can create completely animated presentations that demonstrate products, their packaging, and the assembly of all the parts of virtually any packaging project.

Package the virtual product

As digital technologies mature, many of today’s products are designed with 3D software applications. **3D Connection** brings these product models to ArtiosCAD, assisting designers with the creation of packaging that accurately fits the product. Users can import a wide variety of industry standard 3D formats, including IGES, STEP, SolidWorks, CATIA, Pro Engineer, Inventor and VRML. Using ArtiosCAD’s 3D tools, users can create virtual prototypes and presentations that include the product and its packaging without ever generating samples and proofs.



Think in 3D, design in 3D

Packaging designers often think in 3D but must draw a structural design on a 2-dimensional "drawing board". Now designers can actually start creating packaging designs in 3D with **3D Designer**. Users start with a product model and automatically resize a Standard design to fit the product. The Cross Section and Intersection tools allow users to create internal fitments and windows that follow the product's shape.

3D Designer also creates a variety of 3D models of common packaging products like cans, bottles, glasses and bags. These product models support parametric design, allowing users to resize a single model to create a wide variety of shapes and sizes.

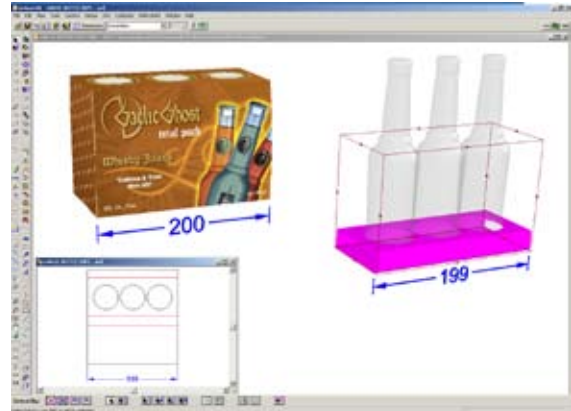

Efficient sheet layouts

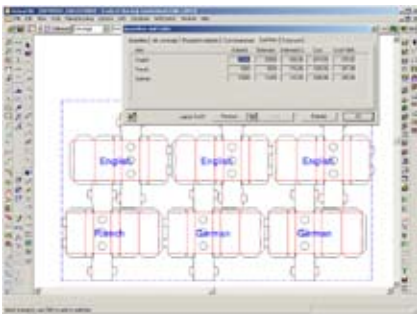

Build sheet layouts quickly and graphically with **Layout**. ArtiosCAD tracks and displays the various graphics used on each design on the sheet. Examine the estimated production cost at each machine in the plant with **Cost/Estimating** and use **Intelligent Layout** to automatically suggest optimum layouts with lowest cost. Standard sheets can be matched to the used printing presses. The proposed solutions can be sorted by variables such as sheet, waste, and number of designs on the sheet. 'Near miss' solutions that require a small reduction in the design are also shown, allowing designers to make minor adjustments to achieve the most efficient layout and reduce costs.

Automated tooling design

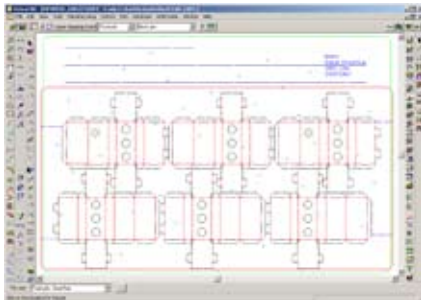

Tooling design has a big impact on the efficiency of your production equipment. ArtiosCAD provides powerful and comprehensive features for dies, counters, stripping sets, rotary tooling and ejection rubber profiles. Fully automated and flexible tooling features quickly design tool sets and the built-in, optimized drivers maximize machine performance. Design dieboards and stripping sets ready for laser cutting with the **DieMaker** and **Stripping** modules. **Rotary DieMaker** builds rotary tooling including die splits, rule paths and bridging on teeth ready for any output including lasers and die saws. Complex counter designs are automatically generated and ready for production with **Intelligent Counters**. Ejection rubber profiles for cutting dies are automatically generated with one-click using the **Rubber Design** module. **Rubber Layout** provides an automatic, optimized cutting layout of the rubber profiles.

Integrated database with comprehensive reporting

To be useful previous design work must be accessible. That's why every ArtiosCAD system uses a relational database for easy and flexible searches. The integrated Database Browsers help designers quickly locate and share design files and information. Users can create reports that 'automatically' format themselves based on the items and information required. 3D thumbnails can be added to reports to help others throughout the company visualize all pieces of any packaging project. ArtiosCAD's Database Reports can be saved in XML, HTML and Excel formats, providing a wide variety of connectivity options for communications with other users and systems.

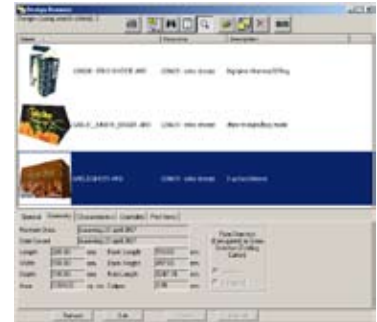

Round trip workflows for structural and graphic designers

EskoArtwork offers an ArtiosCAD Adobe® Illustrator® plugin bundle to enhance productivity and communication between structural and graphic designers. One component imports native ArtiosCAD files into Adobe® Illustrator®, maintains the ArtiosCAD layers and information and provides dedicated tools to preserve CAD data in Adobe® Illustrator®.

The second component exports graphic information from Adobe® Illustrator® directly to ArtiosCAD. This helps structural designers create CAD files that follow graphic outlines – particularly important for designers of displays and folding cartons, where the final package die cut often needs to follow specific graphic features. With these two plugins, EskoArtwork has created the first 'round trip' workflow between structural and graphic designers.

Both plug-ins can be downloaded from the EskoArtwork website www.esko.com



ArtiosCAD integrates into virtually any workflow

Import formats	CFF2, DDES, DDES3, DXF, HPGL, EPS, Elcede
Export formats	CFF2, DDES, DDES3, DXF, HPGL, EPS, Elcede
3D import formats	IGES, STEP, SolidWorks, CATIA, Pro Engineer, VRML
3D export formats	IGES, SolidWorks, Pro Enigeer, VRML, U3D, Animtion-(DOC, PDF and PPT)
Graphic formats	PDF, EPS, JPEG, TIFF, PNG, BMP
Databases	Microsoft MSDE®, Microsoft SQL Server®, 2000, 2005 and Express, Oracle®, 9i, Oracle® 10g
Languages	English, French, German, Italian, Hungarian, Spanish, Japanese, Chinese, Thai, Russian

ArtiosCAD is a member of Esko Software Suite 7, EskoArtworks' advanced workflow environment integrating a number of software products for packaging service providers and commercial printers. The Esko Software Suite covers a wide range of functions, from job management, through graphic and structural design and pre-production operations, to platemaking for printing and toolmaking for converting.